

# iCtP™ NewsWriter™

**ELIMINATE CHEMISTRY  
ELIMINATE FILM  
REDUCE COSTS**



#### **The most space-saving and affordable CtP platesetter of its class**

The NewsWriter™ is an affordable, metal Computer-to-Plate system which produces press-ready aluminum plates for small newspaper applications or commercial printers with daylight operation and without the use of chemical processing. This small footprint CtP solution is completely self-contained and its chemical free approach means no additional equipment (such as chemical processing units or washout units) is required.

#### **Compact semi-automation for small and medium formats**

Setting new standards in cost, flexibility and speed, the NewsWriter™ produces digital CtP plates, which deliver accurate registration and high quality for small to medium format offset printers.

The NewsWriter™'s semi-automated plate registration system provides a versatile plate handling approach so multiple plate sizes and gauges can be used in parallel and with no changes. This makes the Glunz & Jensen NewsWriter™ highly suitable for the smaller newspaper printer with one or more printing presses for commercial printing work as well.

#### **Inkjet technology delivers plates without chemistry**

The NewsWriter™ applies a Liquid Dot™ image on to non-photosensitive aluminum printing plates. The imaged plates are manually fed through an integrated finishing unit, which dries the plates and bonds the liquid dots to the plate surface, enabling up to 50,000 impressions on press.

#### **Low consumption for the benefit of the environment**

The NewsWriter™ has the lowest energy usage in its class and it has the lowest heat output. This also has a positive effect on the energy balance. There is no need for additional air conditioning in up to 32° C (90° F) ambient temperature. The minimal electricity requirement provides substantial long term, cost savings as well as being environmentally friendly.

#### **The real advantage of iCtP**

Of course, the real advantage of iCtP™ is the reduced time making plates, and the fact that the accurate digital plates reduce "time to fit" on press. In addition, the daylight operation and chemistry free approach makes iCtP™ the ideal low maintenance plate making solution.



The NewsWriter™ includes the industry standard Harlequin Postscript RIP. Accepting jobs from Mac or PC in Postscript, PDF, EPS, TIFF & JPEG formats - handling your job, ripping it and outputting it directly to the NewsWriter™.



The NewsWriter™ features a semi-automated plate alignment system to ensure accurate registration and transport through the imaging engine. Semi-automated, a visual Indicator illuminates, based on conductivity as plates are placed in register.



The NewsWriter™ images in daylight and needs no processing chemistry as it uses advanced inkjet technology to add the image to your plate, eliminating any mess or fuss. No more need to maintain or clean chemical processors.

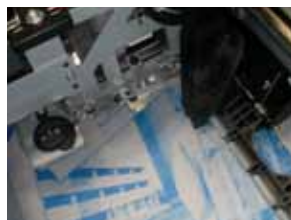

Easy to use - imaging in front of your eyes on to non-photosensitive conventionally grained aluminum plates, the NewsWriter™ delivers a standard metal plate for your pressroom that requires no pressroom changes.



Imaged plates are fed through the integrated Finishing Unit, located below the Print Engine. This finishes the plates by drying and bonding the liquid dots to the plate surface. The Finishing Unit includes a built-in gumming station to apply a protective gum layer.

**GLUNZ & JENSEN**   
PLATESETTING • ICTP

# iCtP™ NewsWriter™



## Technical specifications

Imaging device	10 x 360 Ultra high definition imaging array (3600 dual density nozzles delivering up to 2880 dpi)
Imaging fluid	Patented Liquid Dot™ technology
Plate type	Non-Photosensitive, conventionally grained aluminum plate, optimized for iCtP™ (All sheet fed and most WEB press formats)
Plate thickness	Aluminum 0.15 / 0.20 / 0.30 mm (0.006 / 0.008 / 0.012")
Plate width	203 - 650 mm (8.0 - 25.6")
Plate length	279 - 915 mm (11.0 - 36")
Max imaging size (W x L)	609 x 896 mm (24.0 x 35.26")
Plate finishing	Automated integral gumming system
Imaging resolution	1440 x 1440 / 1440 x 2880 or 2800 x 2800 dpi
Imaging speed	9 - 17 plates/hour for plate format 318 x 559 mm (12.5 x 22") 8 - 13 plates/hour for plate format 585 x 635 mm (23 x 25") 8 - 10 plates/hour for plate format 586 x 889 mm (23.06 x 35") Imaging speed is dependent on plate format, image coverage and resolution.
Run length	50,000 impressions
RIP	Harlequin based RIP platform: 2GB RAM, 100 BaseT ethernet with connectivity to MAC and PC environments
Screening modes	Conventional Halftone (AM) screening for Newspapers up to 133 lpi (52 lpcm) or Stochastic screening, optimized for iCtP™ ensuring moiré free prints (for ink saving on press)
Power supply	100 to 230 VAC, 50/60 Hz
Power consumption	Stand by: 0.3 kW Process: 3 kW
Operating environment	Temperature range 15 - 32°C (59 - 90°F); 20°C (68°F) or higher recommended
Humidity range	35 to 80% (no condensation)
Footprint (L x W x H)	2765 x 1360 x 1338 mm (108.9 x 53.5 x 52.7")
Weight	Crated: 320 kg (705 lbs) Non crated: 215 kg (474 lbs)
Standard equipment	NewsWriter™ high definition Inkjet Print Engine, Finishing unit including baking, gumming and dryer system, feed and delivery table, stand for NewsWriter™, RIP workstation with Mac and PC connectivity, Harlequin based Xitron RIP with iScreening technology, basic colour proofing support for Epson 4800/4880, 7800/7880, 9800/9880, and fluid start-up kit.

NB: This brochure was printed on a Heidelberg® Speedmaster with plates created on a NewsWriter™ system.

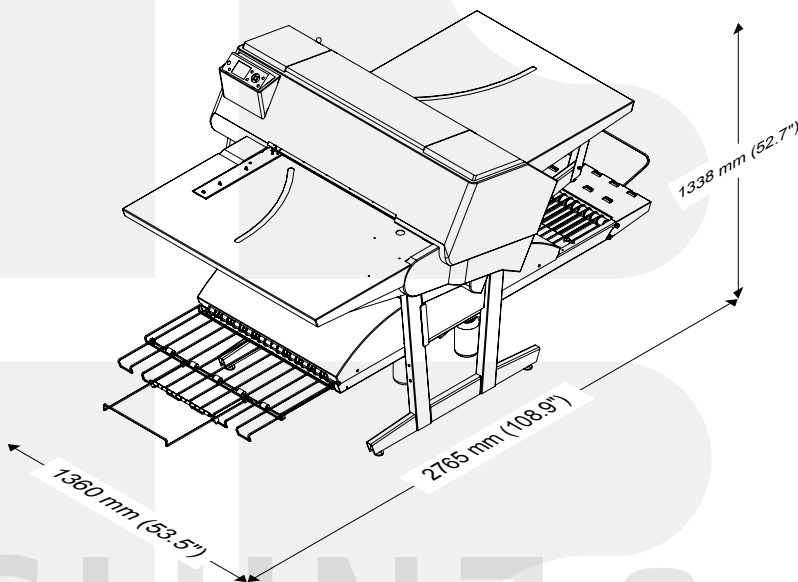

## GLUNZ & JENSEN

Headquarters:  
Glunz & Jensen A/S  
Haslevvej 13  
DK-4100 Ringsted  
Denmark  
Tel. +45 57 68 81 81  
Fax +45 57 68 83 40  
ictp@glunz-jensen.com

Glunz & Jensen, Inc.  
12633 Industrial Drive  
Granger, IN 46530  
USA  
Tel. +1 574 272 9950  
Fax +1 574 277 6566  
ictp@glunz-jensen.com

[www.platewriter.com](http://www.platewriter.com)